

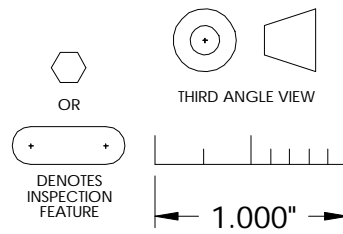

FOR REFERENCE ONLY

REVISIONS - AP101168

REV	DESCRIPTION	DATE/BY	ECN NO.

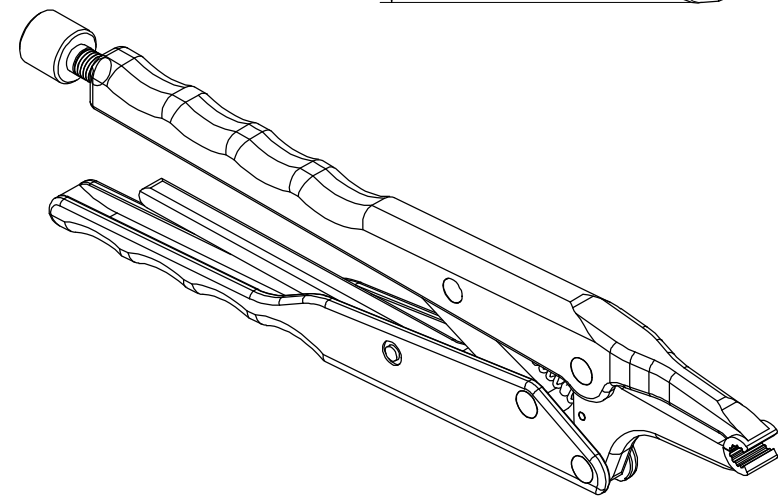
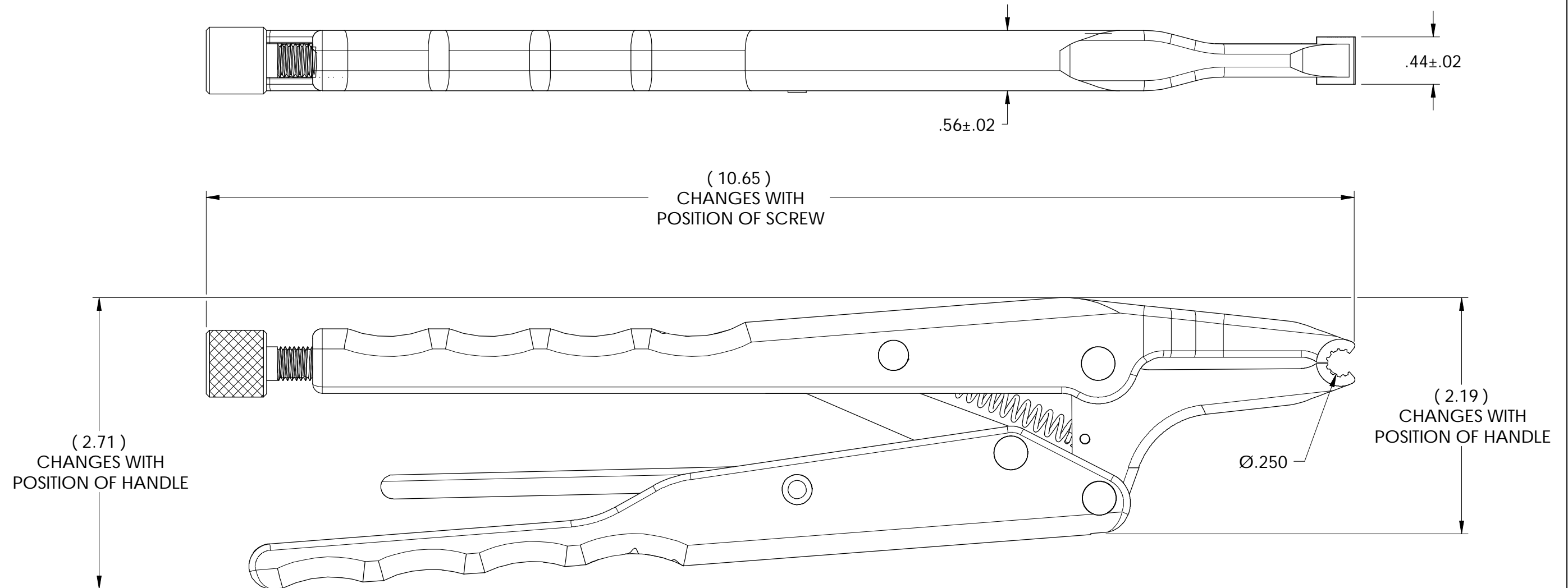

THIS DOCUMENT INCLUDING ALL DATA, SPECIFICATIONS, AND INFORMATION CONTAINED WITHIN IS CONFIDENTIAL AND PROPRIETARY TO BEERE PRECISION MEDICAL INSTRUMENTS BY RETENTION. THE RECIPIENT AGREES NOT TO REPRODUCE, DISCLOSE, OR MAKE USE OF ITS CONTENTS IN ANY WAY, WITHOUT PRIOR WRITTEN PERMISSION OF AN OFFICER OF BEERE PRECISION MEDICAL INSTRUMENTS.

AP101168	MATERIAL	HANDLE: 17-4 PH SST		UNSPECIFIED TOLERANCES		 5307 95TH AVE KENOSHA, WI 53144 (262) 657-2800	
	HEAT TREAT	H900 42±2 Rc H950 47 ±2 Rc		.X ±.020 .XX ±.010 .XXX ±.005 .XXXX ±.0005	ANGLE ±1° MACHINE FINISH 32		
	FINISH	SCOTCHBRITE AS NEEDED PASSIVATE PER MP-001		CONCENTRICITY .005 T.I.R. SQUARENESS .005 T.I.R.		TITLE ADJ PLR Ø.250 R-ROTR	
	REMOVE ALL BURRS		BREAK SHARP CORNERS		DO NOT SCALE DRAWING		
	PART TO BE FREE OF DIRT, OIL AND CONTAMINANTS		DRAWN	DATE	SIZE	SUPERSEDED NO.	DRAWING NO.
		MTG	11/27/96	B		AP101168	D
		APPROVED	DATE	SCALE	1:1	ILLUSTRATION	SHEET 1 OF 1