

FOR REFERENCE ONLY

REVISIONS - BP211001-___(cc)

REV	DESCRIPTION	DATE/BY	DCN NO.

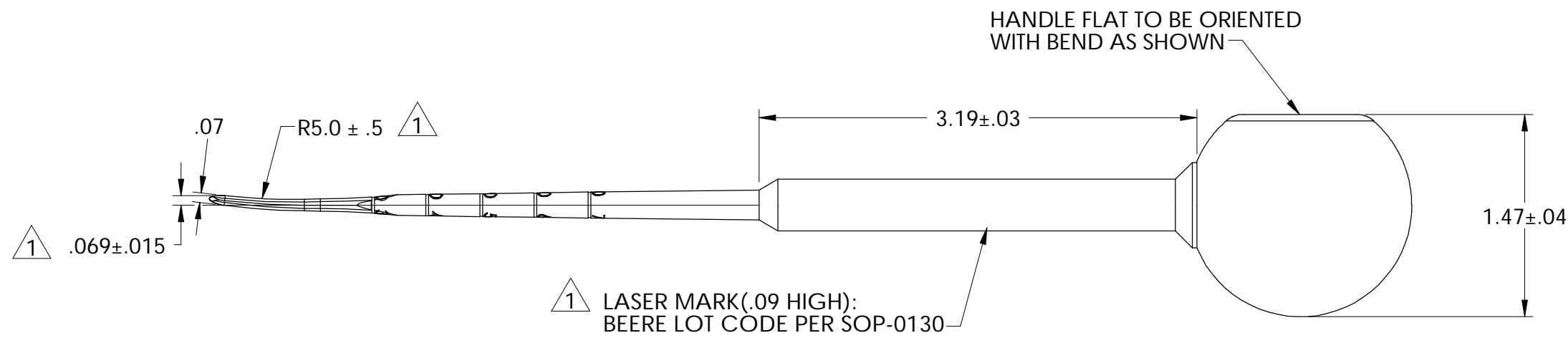
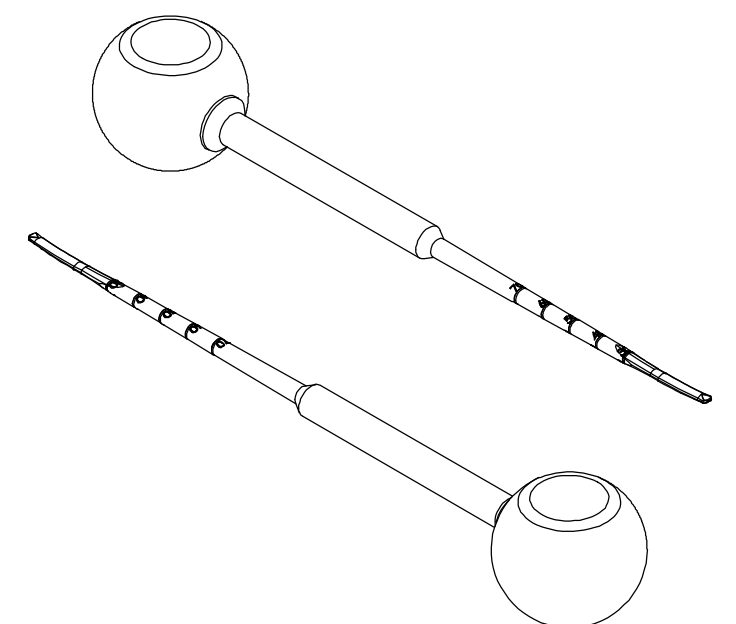
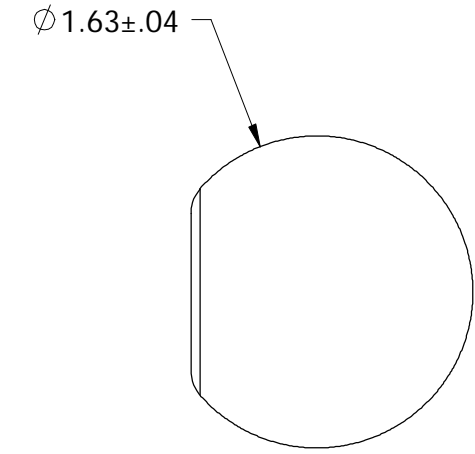
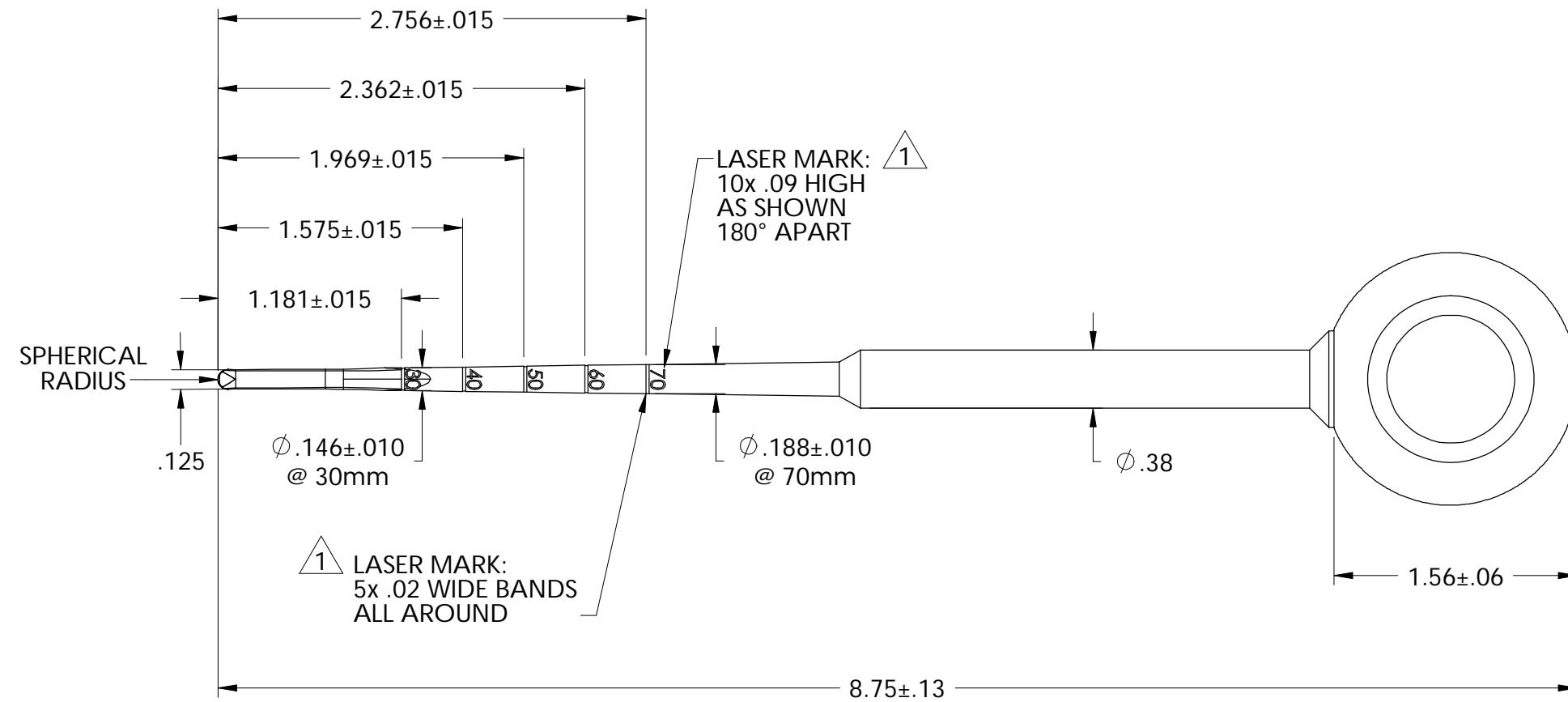

1 UNLESS OTHERWISE SPECIFIED

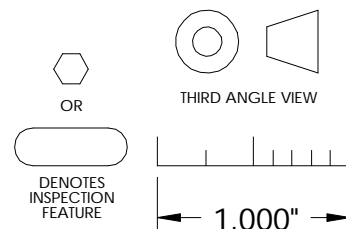

THIS DOCUMENT INCLUDING ALL DATA, SPECIFICATIONS, AND INFORMATION CONTAINED WITHIN IS CONFIDENTIAL AND PROPRIETARY TO BEERE PRECISION MEDICAL INSTRUMENTS BY RETENTION. THE RECIPIENT AGREES NOT TO REPRODUCE, DISCLOSE, OR MAKE USE OF ITS CONTENTS IN ANY WAY, WITHOUT PRIOR WRITTEN PERMISSION OF AN OFFICER OF BEERE PRECISION MEDICAL INSTRUMENTS.

BP211001-___(cc)	MATERIAL	UNSPECIFIED TOLERANCES		beere PRECISION medical INSTRUMENTS 5307 95TH AVE KENOSHA, WI 53144 (262) 657-2800	
	HEAT TREAT	X ±.020 XX ±.010 XXX ±.005 XXXX ±.0005	ANGLE ±1° MACHINE FINISH 32		
	FINISH	CONCENTRICITY .005 T.I.R. SQUARENESS .005 T.I.R.		TITLE B-PRB, CRV BALL .125W S-TPR 8.75"	
	REMOVE ALL BURRS BREAK SHARP CORNERS PART TO BE FREE OF DIRT, OIL AND CONTAMINANTS	DRAWN JMW APPROVED	DATE 11/12/03 DATE	SIZE B SCALE 1:1	SUPERSEDED NO.
				REV A	SHEET 1 OF 1