

FOR REFERENCE ONLY

REVISIONS - DB204006-___-___(cc)			
REV	DESCRIPTION	DATE/BY	ECN NO.

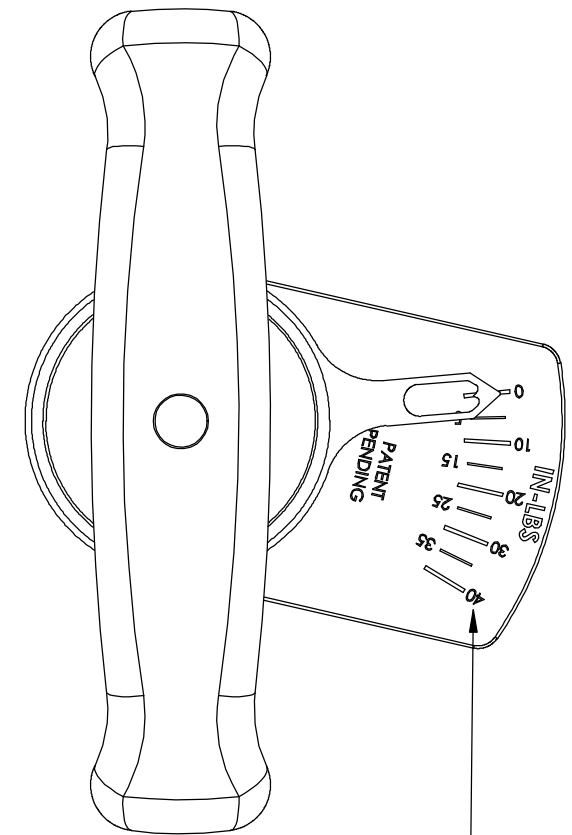
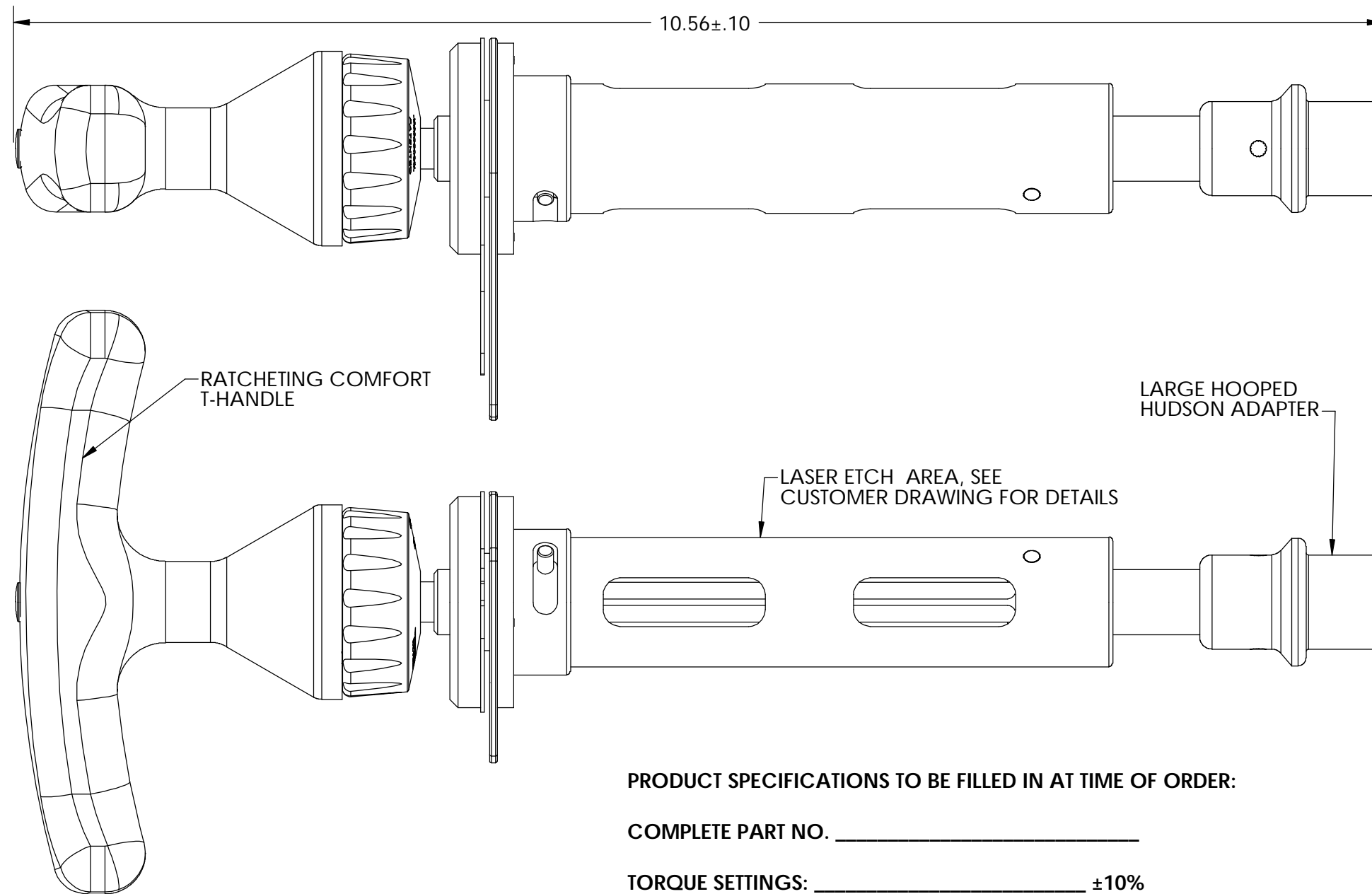

LEFT SIDE VIEW

(REFERENCE ONLY)
TORQUE MARKINGS, SEE CUSTOMER DRAWING FOR SPECIFICATIONS

PRODUCT SPECIFICATIONS TO BE FILLED IN AT TIME OF ORDER:

COMPLETE PART NO. _____

TORQUE SETTINGS: _____ ±10%

COLOR OF HANDLE: _____

APPROVAL/DATE: _____

NOTE:

1. T-HANDLE IS PERMANENTLY ATTACHED TO BEAM.
2. DEFLECTION BEAM IS NON-CANNULATED.
3. FUNCTION TEST HUDSON.
4. CHECK ALL LASER MARKINGS
5. TORQUE MARKING LOCATION/SPACING TO BE DETERMINED AT FINAL ASSEMBLY/CALIBRATION, PER CUSTOMER SPECIFICATIONS.

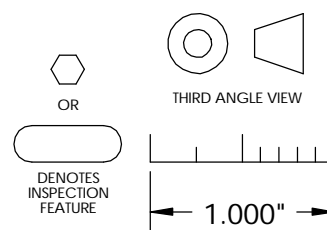

PART NUMBER	MAXIMUM TORQUE	SCALE PLATE
DB204006-040-___(cc)	40 IN-LBS (4.5Nm)	204-0044A
DB204006-050-___(cc)	80 IN-LBS (9.0Nm)	204-0045A
DB204006-060-___(cc)	120 IN-LBS (13.5Nm)	204-0046A
DB204006-065-___(cc)	150 IN-LBS (17Nm)	204-0057A
DB204006-070-___(cc)	160 IN-LBS (18Nm)	204-0047A

THIS DOCUMENT INCLUDING ALL DATA, SPECIFICATIONS, AND INFORMATION CONTAINED WITHIN IS CONFIDENTIAL AND PROPRIETARY TO BEERE PRECISION MEDICAL INSTRUMENTS BY RETENTION. THE RECIPIENT AGREES NOT TO REPRODUCE, DISCLOSE, OR MAKE USE OF ITS CONTENTS IN ANY WAY, WITHOUT PRIOR WRITTEN PERMISSION OF AN OFFICER OF BEERE PRECISION MEDICAL INSTRUMENTS.

DB204006-___(cc)	MATERIAL	UNSPECIFIED TOLERANCES				5307 95TH AVE KENOSHA, WI 53144 (262) 657-2800	
	HEAT TREAT	.X ±.020 .XX ±.010 .XXX ±.005 .XXXX ±.0005	ANGLE ±1° MACHINE FINISH 32				
	FINISH	CONCENTRICITY .005 T.I.R. SQUARENESS .005 T.I.R.		TITLE RTCH T-HDL AXIAL D-BM LG HPD FEM HUD		SIZE B SUPERSEDED NO. DRAWING NO. DB204006-___-___(cc) REV B	
	REMOVE ALL BURRS	DO NOT SCALE DRAWING					
PART TO BE FREE OF DIRT, OIL AND CONTAMINANTS		DATE 08/20/01	DATE	ILLUSTRATION			