

FOR REFERENCE ONLY

STYLE	MATERIAL (BASE)	FINISH (REFERENCE)	TREATMENT (REFERENCE)
SS	17-4 13-8	SATIN BRUSH	PASSIVATE PER WI-0006
Ti	6Al-4V	SATIN BRUSH	NONE
CR	6Al-4V	SATIN BRUSH	CrN COATING

REVISIONS - PA312100-___			
REV	DESCRIPTION	DATE/BY	ECN NO.

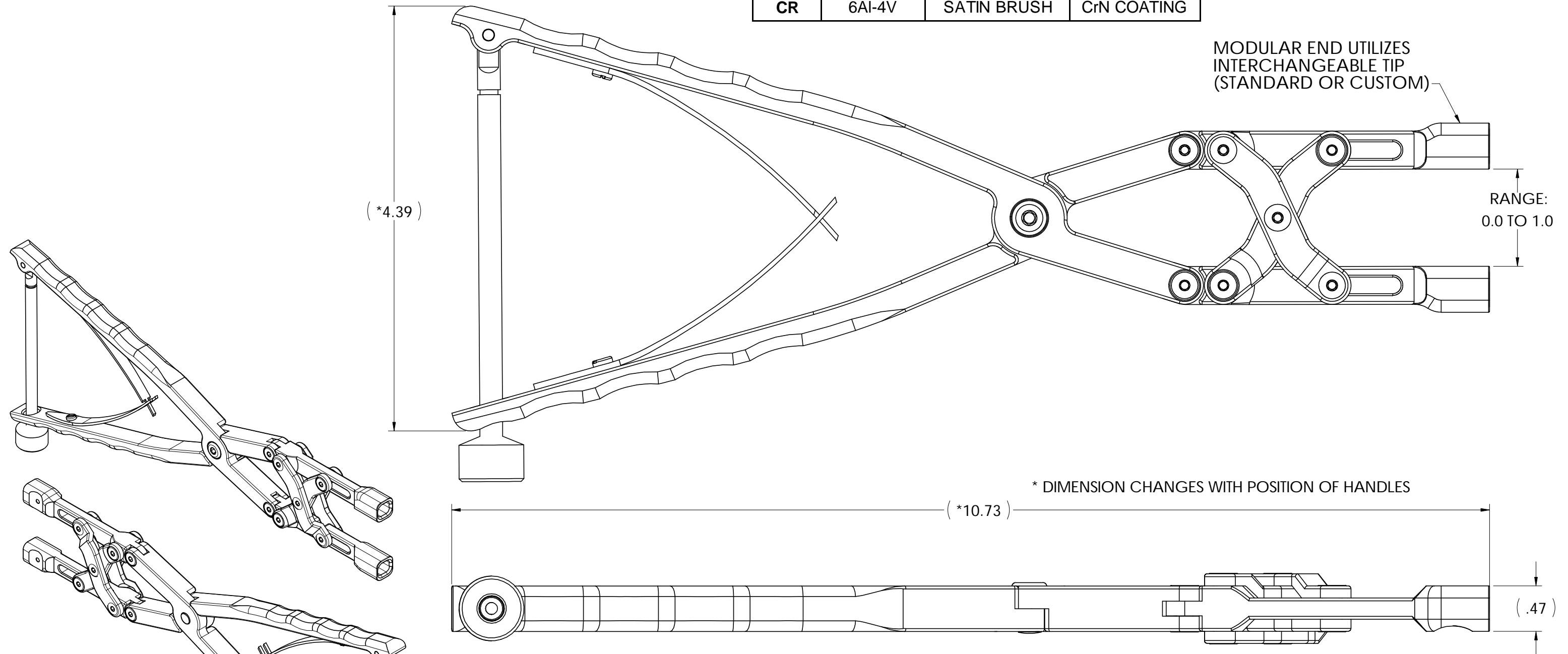

THIS DOCUMENT INCLUDING ALL DATA, SPECIFICATIONS, AND INFORMATION CONTAINED WITHIN IS CONFIDENTIAL AND PROPRIETARY TO BEERE PRECISION MEDICAL INSTRUMENTS BY RETENTION. THE RECIPIENT AGREES NOT TO REPRODUCE, DISCLOSE, OR MAKE USE OF ITS CONTENTS IN ANY WAY, WITHOUT PRIOR WRITTEN PERMISSION OF AN OFFICER OF BEERE PRECISION MEDICAL INSTRUMENTS.

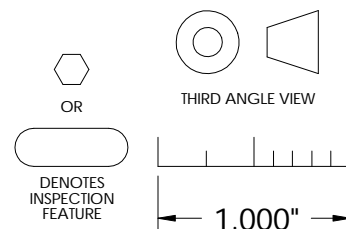

PA312100-___	MATERIAL	SEE CHART	UNSPECIFIED TOLERANCES			5307 95TH AVE KENOSHA, WI 53144 (262) 657-2800				
	HEAT TREAT	N/A	.X ±.020 .XX ±.010 .XXX ±.005 .XXXX ±.0005	ANGLE ±1° MACHINE FINISH 32/		TITLE				
	FINISH	SEE CHART	CONCENTRICITY .005 T.I.R. SQUARENESS .005 T.I.R.		CMPR, PRL ACT INTCHG JAW					
	REMOVE ALL BURRS BREAK SHARP CORNERS		DO NOT SCALE DRAWING		DRAWN	JAR	DATE	11/22/00		
PART TO BE FREE OF DIRT, OIL AND CONTAMINANTS		APPROVED	DATE	SIZE	B	SUPERSEDED NO.	DRAWING NO.	PA312100-___	REV	C
				SCALE	1:1		ILLUSTRATION	SHEET	1 OF 1	