

FOR REFERENCE ONLY

REVISIONS - PA712200-___			
REV	DESCRIPTION	DATE/BY	DCN NO.

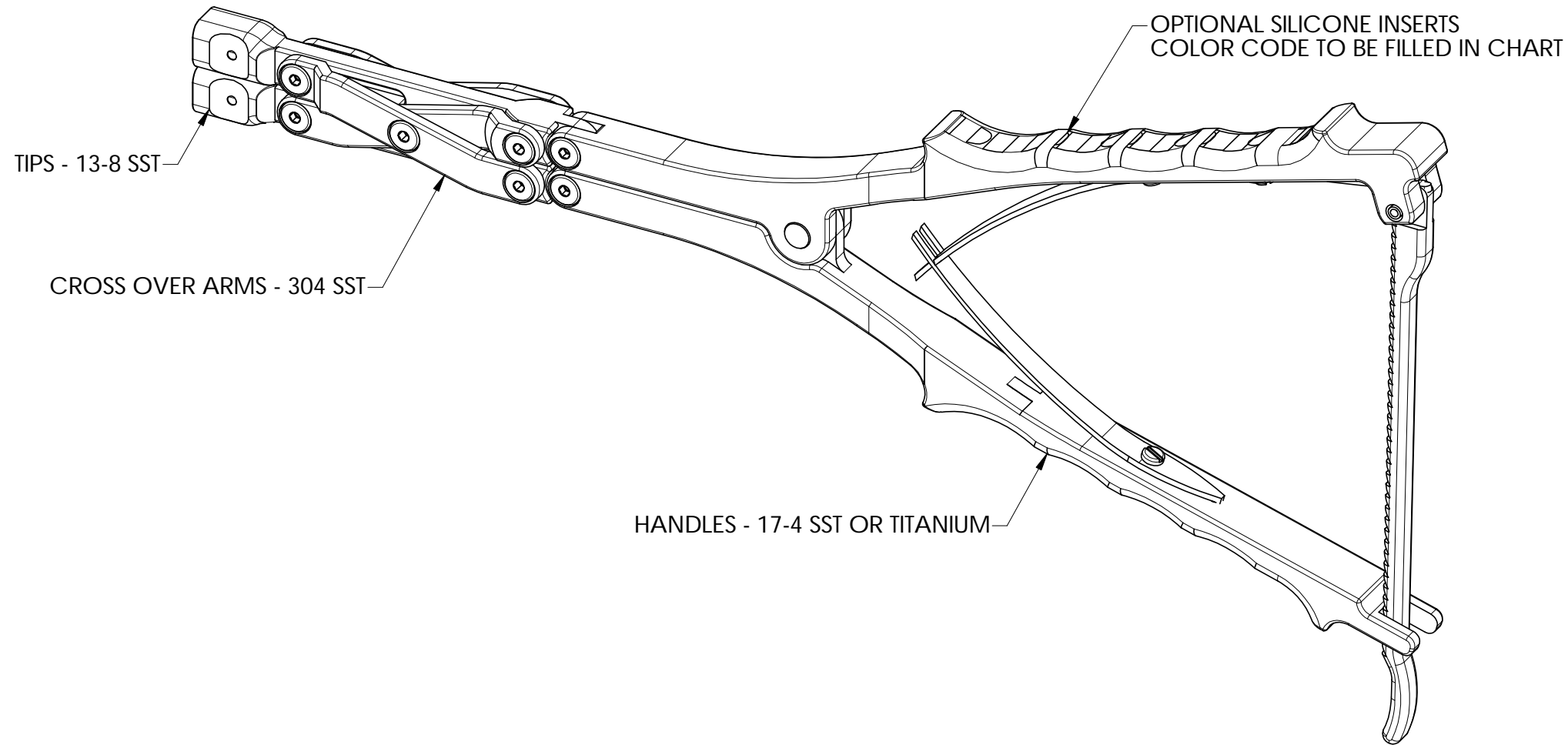

HANDLE STYLE	MATERIAL (BASE)	FINISH	TREATMENT (SURFACE)
SS	17-4	(SATIN BRUSH)	(PASSIVATED)
Ti	6Al-4V	(SATIN BRUSH)	NONE
CR	6Al-4V	(SATIN BRUSH)	(CrN COATING)

**NOTE:
SHOWN WITHOUT INSERTS**

***FINAL DRAWING NUMBER CONFIGURED PER CHART SPECIFICATIONS**

DRAWING NO.	ASSY DESCRIPTION	INSERT
PA712200-___	DSTR, INTEG PRL ACT 1.5", RAK, INTCHG JAW	NONE
PA712200-___-___(cc)	DSTR, INTEG PRL ACT 1.5", RAK, INSR SIL, INTCHG JAW	242-0003___(cc)

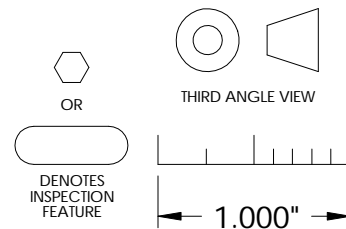

PA712200-___	MATERIAL	SEE COMPONENTS		UNSPECIFIED TOLERANCES			5307 95TH AVE KENOSHA, WI 53144 (262) 657-2800		
	HEAT TREAT	NONE		.X ±.020 .XX ±.010 .XXX ±.005 .XXXX ±.0005	ANGLE ±1° MACHINE FINISH 32		DSTR, PRL ACT 1.5" STROKE, INTCHG JAW		
	FINISH	NONE		CONCENTRICITY .005 T.I.R. SQUARENESS .005 T.I.R.		TITLE			
	REMOVE ALL BURRS BREAK SHARP CORNERS				DO NOT SCALE DRAWING		DRAWN TJM DATE 08/13/02 APPROVED DATE		
PART TO BE FREE OF DIRT, OIL AND CONTAMINANTS				SCALE 3:4		SIZE B SUPERSEDED NO. PA802200 DRAWING NO. PA712200-___ REV D		SHEET 1 OF 2	

THIS DOCUMENT INCLUDING ALL DATA, SPECIFICATIONS, AND INFORMATION CONTAINED WITHIN IS CONFIDENTIAL AND PROPRIETARY TO BEERE PRECISION MEDICAL INSTRUMENTS BY RETENTION. THE RECIPIENT AGREES NOT TO REPRODUCE, DISCLOSE, OR MAKE USE OF ITS CONTENTS IN ANY WAY, WITHOUT PRIOR WRITTEN PERMISSION OF AN OFFICER OF BEERE PRECISION MEDICAL INSTRUMENTS.

FOR REFERENCE ONLY

STYLE	MATERIAL (BASE)	FINISH	TREATMENT (SURFACE)
SS	17-4 13-8	(SATIN BRUSH)	(PASSIVATED)
Ti	6Al-4V	(GLASS BEAD)	(PTFE)
CR	6Al-4V	(GLASS BEAD)	(CHROME PLATE)

REVISIONS - PA712200-___			
REV	DESCRIPTION	DATE/BY	ECN NO.

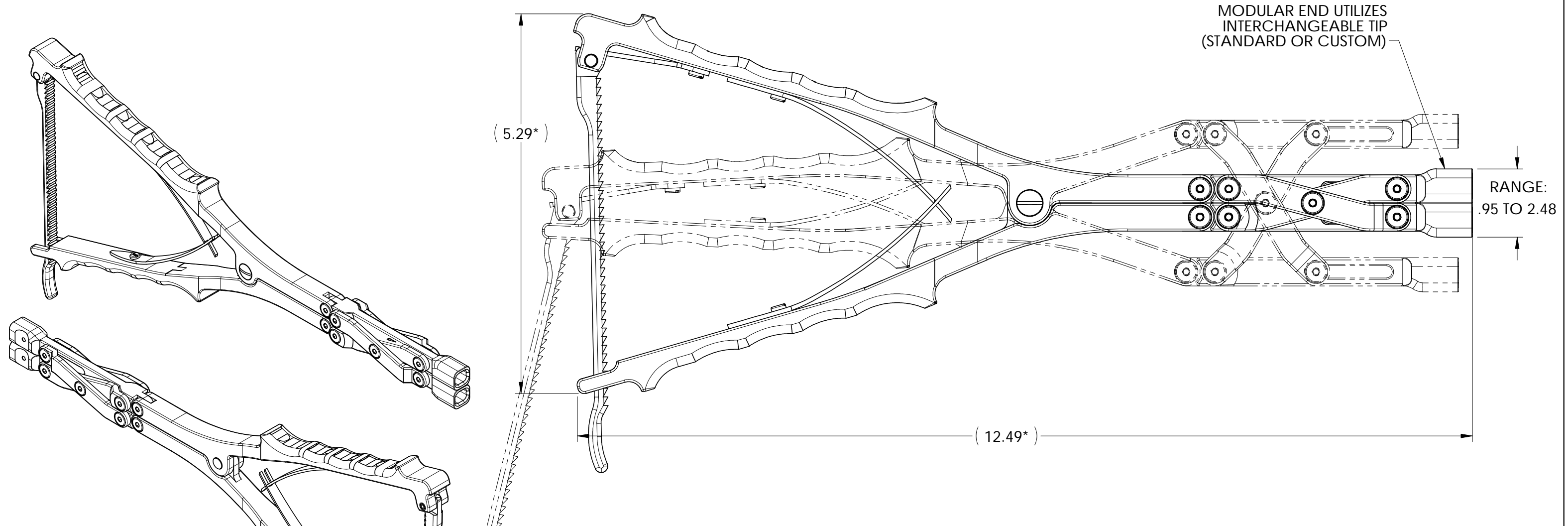

*** NOTE: DIMENSION CHANGES WITH POSITION OF HANDLES**

THIS DOCUMENT INCLUDING ALL DATA, SPECIFICATIONS, AND INFORMATION CONTAINED WITHIN IS CONFIDENTIAL AND PROPRIETARY TO BEERE PRECISION MEDICAL INSTRUMENTS BY RETENTION. THE RECIPIENT AGREES NOT TO REPRODUCE, DISCLOSE, OR MAKE USE OF ITS CONTENTS IN ANY WAY, WITHOUT PRIOR WRITTEN PERMISSION OF AN OFFICER OF BEERE PRECISION MEDICAL INSTRUMENTS.

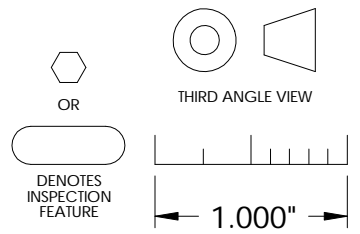

PA712200-___	MATERIAL	SEE COMPONENTS	UNSPECIFIED TOLERANCES			5307 95TH AVE KENOSHA, WI 53144 (262) 657-2800		
	HEAT TREAT	NONE	.X ±.020 .XX ±.010 .XXX ±.005 .XXXX ±.0005	ANGLE ±1° MACHINE FINISH 32/		TITLE DSTR, PRL ACT 1.5" STROKE, INTCHG JAW		
	FINISH	NONE	CONCENTRICITY .005 T.I.R. SQUARENESS .005 T.I.R. DO NOT SCALE DRAWING		SIZE			
	REMOVE ALL BURRS	BREAK SHARP CORNERS	DATE	DATE	B	PA802200	PA712200-___	REV
PART TO BE FREE OF DIRT, OIL AND CONTAMINANTS		APPROVED	TJM	08/13/02	SCALE	3:4	ILLUSTRATION	SHEET 2 OF 2