

FOR REFERENCE ONLY

REVISIONS - PA712202

REV	DESCRIPTION	DATE/BY	ECN NO.

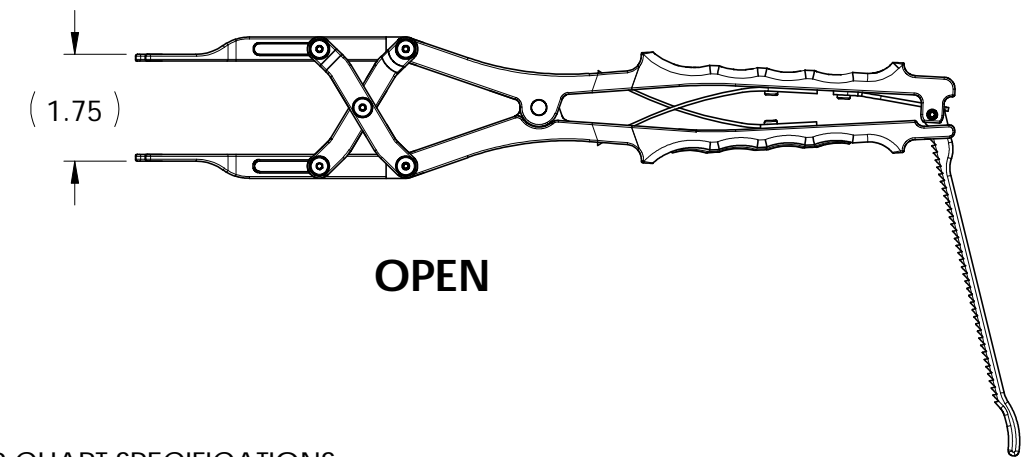
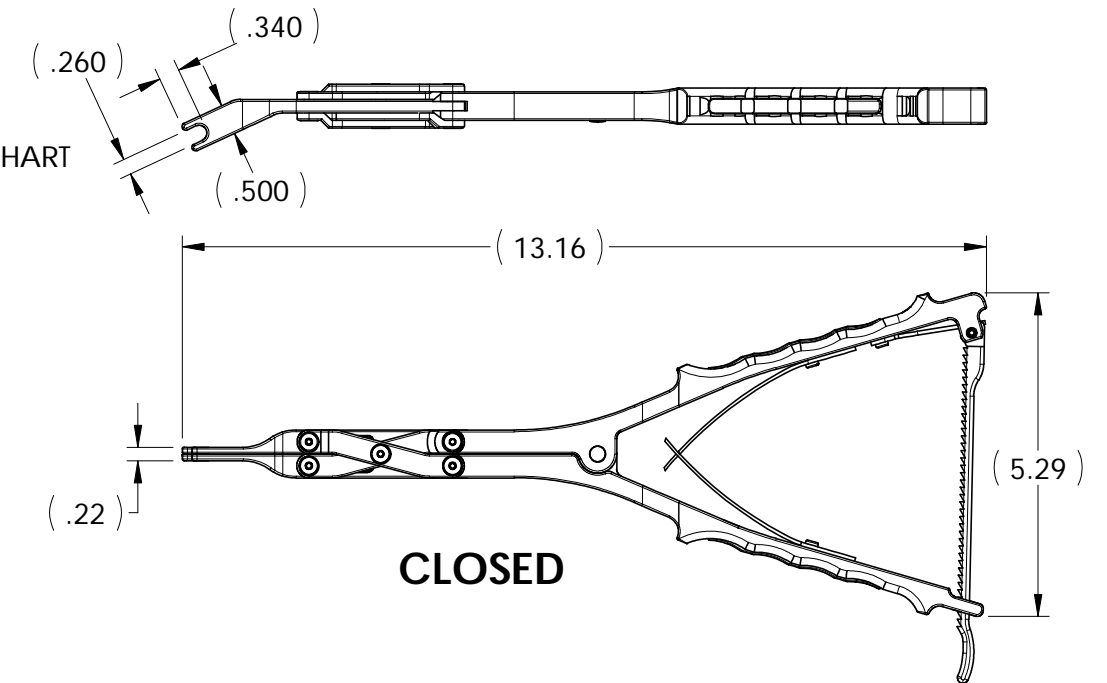
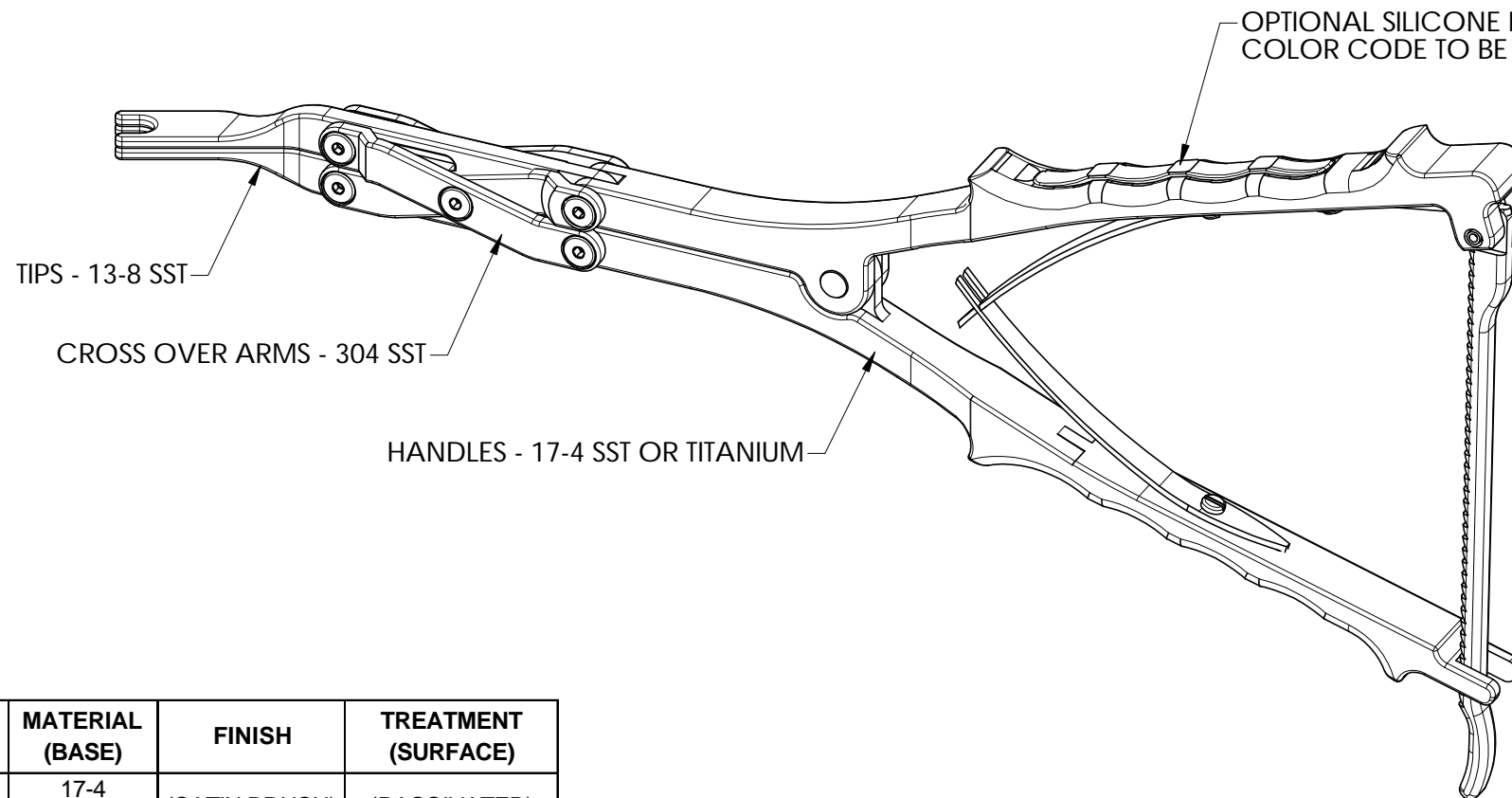

HANDLE STYLE	MATERIAL (BASE)	FINISH	TREATMENT (SURFACE)
SS	17-4 13-8	(SATIN BRUSH)	(PASSIVATED)
Ti	6Al-4V	(SATIN BRUSH)	NONE
CR	6Al-4V	(SATIN BRUSH)	(CrN COATING)

DRAWING NO.	ASSY DESCRIPTION	INSERT
PA712202-___	DSTR, INTEG PRL ACT 1.5", RAK	NONE
PA712202-___-___(cc)	DSTR, INTEG PRL ACT 1.5", RAK, INSR SIL	242-0003___(cc)

**NOTE:
SHOWN WITH INSERTS**

*FINAL DRAWING NUMBER CONFIGURED PER CHART SPECIFICATIONS

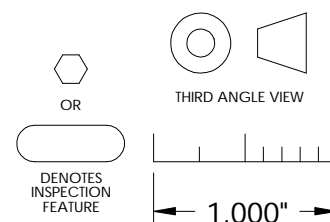

THIS DOCUMENT INCLUDING ALL DATA, SPECIFICATIONS, AND INFORMATION CONTAINED WITHIN IS CONFIDENTIAL AND PROPRIETARY TO BEERE PRECISION MEDICAL INSTRUMENTS BY RETENTION. THE RECIPIENT AGREES NOT TO REPRODUCE, DISCLOSE, OR MAKE USE OF ITS CONTENTS IN ANY WAY, WITHOUT PRIOR WRITTEN PERMISSION OF AN OFFICER OF BEERE PRECISION MEDICAL INSTRUMENTS.

PA712202	MATERIAL	SEE DETAILS		UNSPECIFIED TOLERANCES		beere PRECISION medical INSTRUMENTS 5307 95TH AVE KENOSHA, WI 53144 (262) 657-2800	
	HEAT TREAT			.X ±.020 .XX ±.010 .XXX ±.005 .XXXX ±.0005	ANGLE ±1° MACHINE FINISH 32/		
	FINISH			CONCENTRICITY .005 T.I.R. SQUARENESS .005 T.I.R.		TITLE DSTR, INTEG PRL ACT 1.5", RAK, SIL INSR	
	REMOVE ALL BURRS		BREAK SHARP CORNERS		DO NOT SCALE DRAWING		
PART TO BE FREE OF DIRT, OIL AND CONTAMINANTS		DRAWN	TJM	DATE	10/13/03	SIZE	B
		APPROVED		DATE		SUPERSEDED NO.	
						DRAWING NO.	PA712202
						REV	02
						SCALE	2:3
						ILLUSTRATION	SHEET 1 OF 1