

FOR REFERENCE ONLY

REVISIONS: PR311000-___(cc)

REV	DESCRIPTION	DATE/BY	DCN
-----	-------------	---------	-----

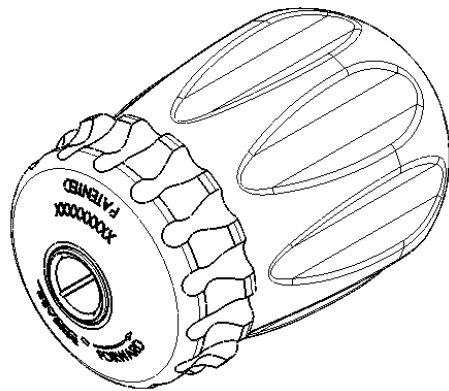
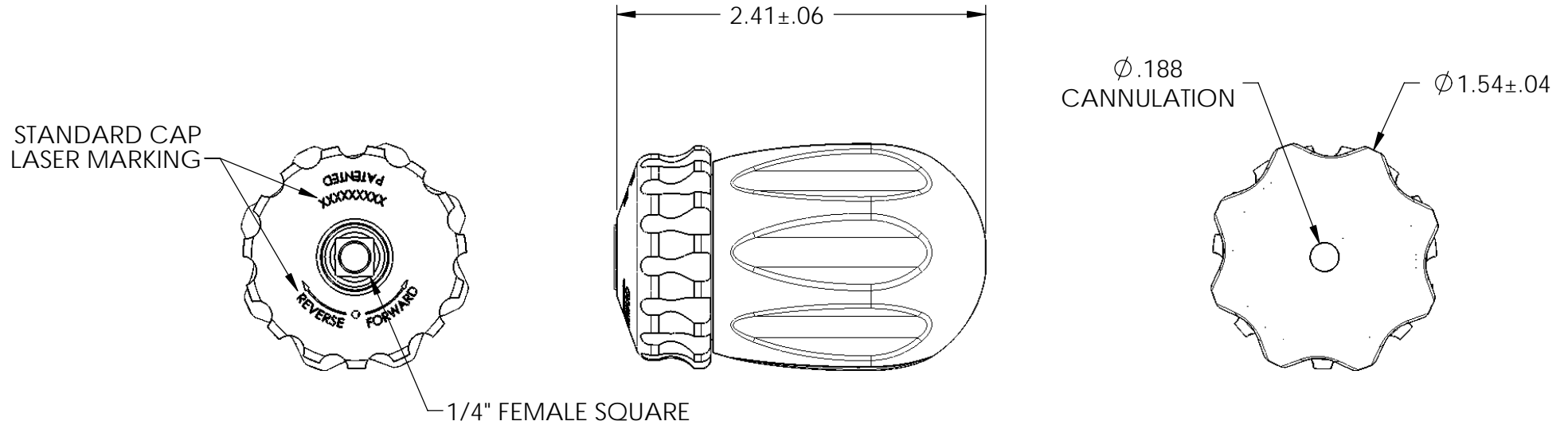

THIS DOCUMENT INCLUDING ALL DATA, SPECIFICATIONS, AND INFORMATION CONTAINED WITHIN IS CONFIDENTIAL AND PROPRIETARY TO TELEFLEX MEDICAL BY RETENTION. THE RECIPIENT AGREES NOT TO REPRODUCE, DISCLOSE, OR MAKE USE OF ITS CONTENTS IN ANY WAY WITHOUT PRIOR WRITTEN PERMISSION OF AN OFFICER OF TELEFLEX MEDICAL.

CUSTOMER REF		MATERIAL		UNSPECIFIED TOLERANCES INCHES		 <small>beere KMedic</small> <small>5307 95th Avenue</small> <small>Kenosha, WI 53144, USA</small> <small>Phone: 262-657-2800</small> <small>Fax: 262-657-2801</small> <small>www.teleflexmedicaloem.com</small>																									
SOLIDMODEL PR311000-___(cc)		HEAT TREAT		<table border="0"> <tr> <td>X</td><td>+/- .020</td> <td>ANGLE</td><td>+/- 1°</td> </tr> <tr> <td>.XX</td><td>+/- .010</td> <td>MACHINE</td><td></td> </tr> <tr> <td>.XXX</td><td>+/- .005</td> <td>FINISH</td><td>✓ 32</td> </tr> <tr> <td>.XXXX</td><td>+/- .0005</td> <td></td><td></td> </tr> </table>		X	+/- .020	ANGLE	+/- 1°	.XX	+/- .010	MACHINE		.XXX	+/- .005	FINISH	✓ 32	.XXXX	+/- .0005			TITLE RTCL, PLM CANN 1/4 SQ FEM									
X	+/- .020	ANGLE	+/- 1°																												
.XX	+/- .010	MACHINE																													
.XXX	+/- .005	FINISH	✓ 32																												
.XXXX	+/- .0005																														
FORGING		FINISH		<table border="0"> <tr> <td>CONCENTRICITY</td><td>.005 T.I.R.</td> </tr> <tr> <td>SQUARENESS</td><td>.001 PER. IN.</td> </tr> </table>		CONCENTRICITY	.005 T.I.R.	SQUARENESS	.001 PER. IN.	DRAWING NO. PR311000-___(cc)																					
CONCENTRICITY	.005 T.I.R.																														
SQUARENESS	.001 PER. IN.																														
<table border="0"> <tr> <td></td> <td>OR</td> <td></td> </tr> <tr> <td colspan="3">DENOTES INSPECTION FEATURE</td> </tr> </table>			OR		DENOTES INSPECTION FEATURE			<table border="0"> <tr> <td>REMOVE ALL BURRS</td> <td>BREAK SHARP CORNERS</td> </tr> <tr> <td colspan="2">PART TO BE FREE OF DIRT, OIL, AND CONTAMINANTS</td> </tr> </table>		REMOVE ALL BURRS	BREAK SHARP CORNERS	PART TO BE FREE OF DIRT, OIL, AND CONTAMINANTS		<table border="0"> <tr> <td>DRAWN</td><td>DATE</td> <td>SIZE</td><td>SUPERSEDED NO.</td> </tr> <tr> <td>CER</td><td>03/12/08</td> <td>A</td><td></td> </tr> <tr> <td>APPROVED</td><td>DATE</td> <td>SCALE</td><td>UNITS</td> </tr> <tr> <td></td><td></td> <td>1:1</td><td>INCHES</td> </tr> </table>		DRAWN	DATE	SIZE	SUPERSEDED NO.	CER	03/12/08	A		APPROVED	DATE	SCALE	UNITS			1:1	INCHES
	OR																														
DENOTES INSPECTION FEATURE																															
REMOVE ALL BURRS	BREAK SHARP CORNERS																														
PART TO BE FREE OF DIRT, OIL, AND CONTAMINANTS																															
DRAWN	DATE	SIZE	SUPERSEDED NO.																												
CER	03/12/08	A																													
APPROVED	DATE	SCALE	UNITS																												
		1:1	INCHES																												
THIRD ANGLE VIEW				DRAWING NO. PR311000-___(cc)		REV. A																									
				ILLUSTRATION		SHEET 1 OF 1																									