

# FOR REFERENCE ONLY

REVISIONS: SR635000-\_\_\_(cc)

REV	DESCRIPTION	DATE/BY	DCN
-----	-------------	---------	-----

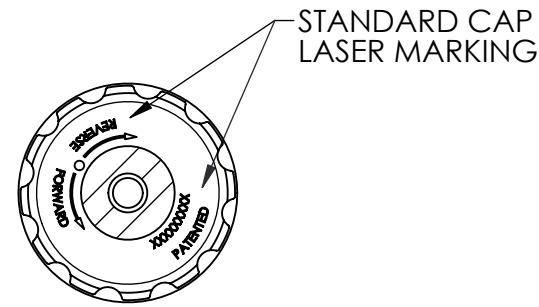
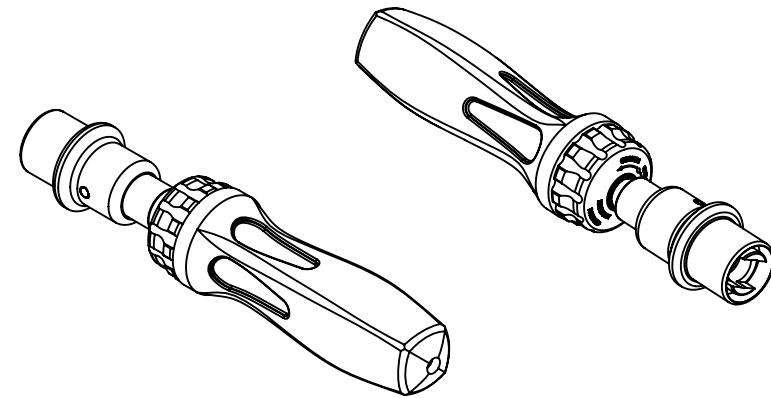

SECTION A-A  
LASER MARKING  
DETAIL

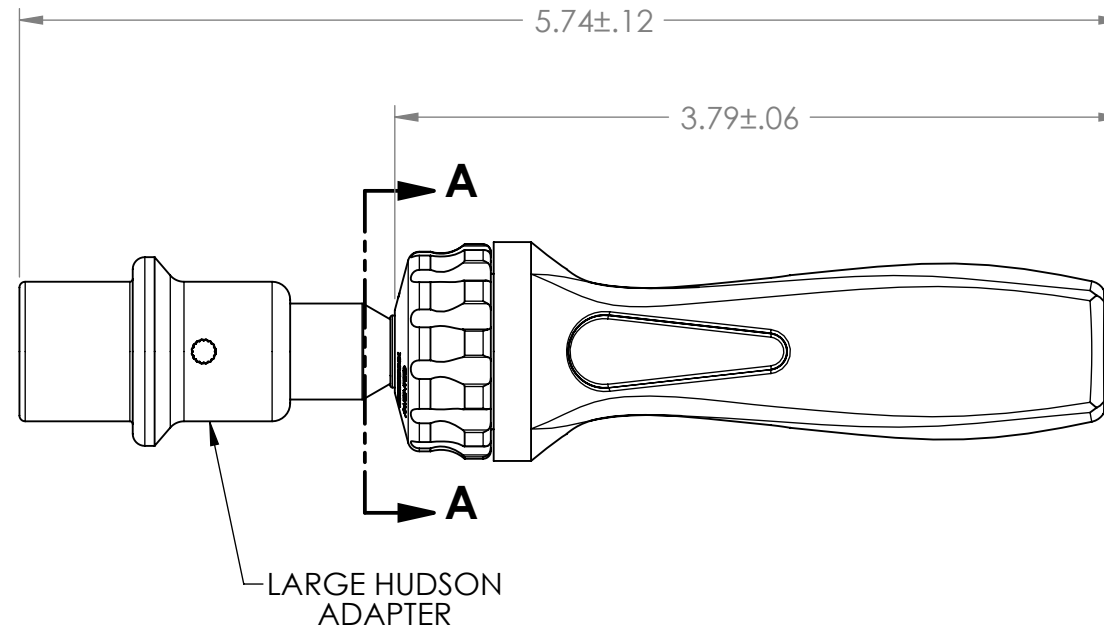
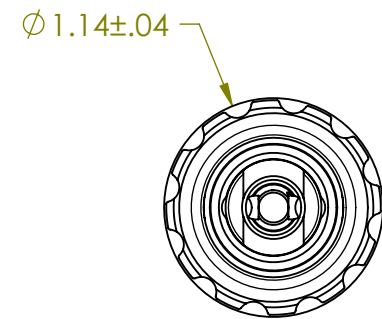

LARGE HUDSON  
ADAPTER

THIS DOCUMENT INCLUDING ALL DATA, SPECIFICATIONS, AND INFORMATION CONTAINED WITHIN IS CONFIDENTIAL AND PROPRIETARY TO TELEFLEX MEDICAL BY RETENTION. THE RECIPIENT AGREES NOT TO REPRODUCE, DISCLOSE, OR MAKE USE OF ITS CONTENTS IN ANY WAY, WITHOUT PRIOR WRITTEN PERMISSION OF AN OFFICER OF TELEFLEX MEDICAL.

SR635000-___(cc)	CUSTOMER REF	MATERIAL	UNSPECIFIED TOLERANCES INCHES		<b>beere   KMedic</b> 5307 95th Avenue Kenosha, WI 53144, USA Phone: 262-657-2800 Fax: 262-657-2801 www.teleflexmedical.com			
	SOLIDMODEL SR635000-___(cc)	HEAT TREAT	.X    +/- .020	ANGLE    +/- 1°				
	FORGING	FINISH	.XX    +/- .010	MACHINE	CONCENTRICITY    .005 T.I.R. SQUARENESS    .001 PER. IN. DO NOT SCALE DRAWING			
	DENOTES INSPECTION FEATURE	REMOVE ALL BURRS    BREAK SHARP CORNERS PART TO BE FREE OF DIRT, OIL AND CONTAMINANTS	.XXX    +/- .005	FINISH    32				
THIRD ANGLE VIEW			DRAWN    REK    DATE    01/25/08	SIZE    B	SUPERSEDED NO.	DRAWING NO.    SR635000-___(cc)	REV    00	
			APPROVED	DATE	SCALE    1:1	UNITS    INCHES	ILLUSTRATION	SHEET    1 OF 1